

INSTRUCTION MANUAL

Frequency control unit for circular and linear vibration feeding devices
Universal Phase Resomat

Typ RM7, RM7-10
Typ RM7U, RM7U-10



Table of Contenes

Safty Instructions	3
Installation & Commissioning	4
General Information	5 - 7
Synchronous Operation Application	8 - 12
Technicel Data	13, 13a
Front Panel Specification	14, 14a, 14b
Equipment Specification	15 - 16
Plug Connectors & Connections	17, 17a
Error Analysis	18
Laboratory Report	19
Declaration of Conformity	20
Appendix	

Safety directions for the user

This description contains the required information for the use as prescribed of the described products. They are intended for qualified technical personnel.

Qualified persons are persons who on account of their training, experience and received instructions as well as their knowledge of relevant standards, regulations, rules for the prevention of accidents and operating conditions have been authorized by the responsible person in charge of the safety of the installation to execute the required work and who are able while doing so to detect and prevent all possible hazards (Definition of skilled labour, according to ICE 364).

Hazard indication

The following directions are for the safety of the service personnel as well as for the safety of the described products and the related devices and machinery.

Warning !

Hazardous voltage

Disregard may cause death, serious injury or heavy damages to the equipment.

- Isolate supply voltage before mounting- and dismantling work as well as in case of fuse replacement or modifications of the structure.
- Observe the specific safety regulations for the prevention of accidents and safety in force for the particular case.
- Check before commissioning if the nominal voltage of the device corresponds to the local mains supply.
- Emergency-Stop installations must be effective in all modes of operation. Unlocking the Emergency Stop installation must not cause an uncontrolled re-start of the device.

Use as prescribed

The devices described herein are electrical equipment for the application in industrial installations. The equipment is designed for the application in control and automation techniques.

Typ RM7U, RM7

Assembly and commissioning

Installation

For the installation of the device, four drill holes are provided on the backside.

Assembly

As heat is created when the equipment is operating, assembling on or close to other sources of heat should be avoided. It should be ensured that an effective strain relief of the connecting leads on the plug-in terminals is achieved.

Commissioning

Before start-up, a check should be made on the power supply services that are available!

- Level of the mains voltage, (the at-system frequency is not a critical factor)
- The nominal output of the conveyor unit (Warning! It must be equipped with AC magnets)
- **NB The conveyor must not be mechanically tuned to the system frequency, (e.g. no mechanical tuning to 60 Hz in areas outside of Europe)**

Setting advice:

The following settings should be only made using the appropriate laboratory equipment (externally adjusted frequency) and the results then applied to this equipment.

Half-wave operation is also possible.

Procedural method:

Firstly, the mechanical resonant frequency is to be determined on the oscillation conveyor system using the RESOMAT. For this, the conveyor pot or the bars should only be loaded with a test part. Then using the RESOMAT, key in the operating frequency. The test part has the highest speed when there is mechanical oscillation. (WARNING! Two or more resonance points are possible). The main resonance point is where the parts are moving at the highest speed. But as the system runs very smoothly in this condition (conveyor speed dependent on attenuation), the output frequency must now be set approx. 1.5Hz higher on the RESOMAT than the mechanical resonance frequency (forced oscillation see Attachment 1). With significant changes in weight up until discharge, an alternative operating point exists on $f_A = f_0 - \Delta 3\text{Hz}$ (Diagram 3). **In this way, the conveyor system becomes mechanically stable and the conveying speed also remains constant.** The final setting of the desired conveying speed is then made using the set-point potentiometer (vibration force) and by selecting the *current pulse wave-shape (see leaflet).

*Complete symmetrical sine-wave form alternating current is an advantage for circular conveyors, as there is no magnetization effect from the solenoids and conveyor parts; also structure-borne noise is reduced to a minimum (no harmonic development).

Having something similar to delta voltage alternating current (turbo effect) is often an advantage for linear bars.

Result:

Not only does the design result in a multiplication of operational the efficiency (see Attachment 2) through energy recovery (reactive-current compensation , but it also gives a high level of stability of the conveying speed and a significant simplification of the mechanical adjustment work through the inphase operation of the oscillation conveyor system using phase resonance equipment.

The RESOMAT provides a symmetrical alternating current at the outlet terminal and that is why there is no disturbing magnetization effect on the conveyor parts and no residual current on the magnets. The output frequency of the RESOMAT is absolutely stable.

General information

Adjustment of the operating point at vibration systems

electrical operating frequency ω_A

$$\omega_A = \omega_0 + \Delta 1,5 \text{ Hz}$$

Result: $y_A = \text{constant}$

- y = elongation (excursion)
- y^R = elongation at mech. resonance
- y^A = elongation at ω_A
- ω = angular frequency
- ω_A = operating frequency, electrical
- ω_0 = mech. resonance frequency
- d = attenuation
- m_0 = mass (weight)
- D = spring constant (spring)
- J = mass moment of inertia
- D^* = angular recommended dimension

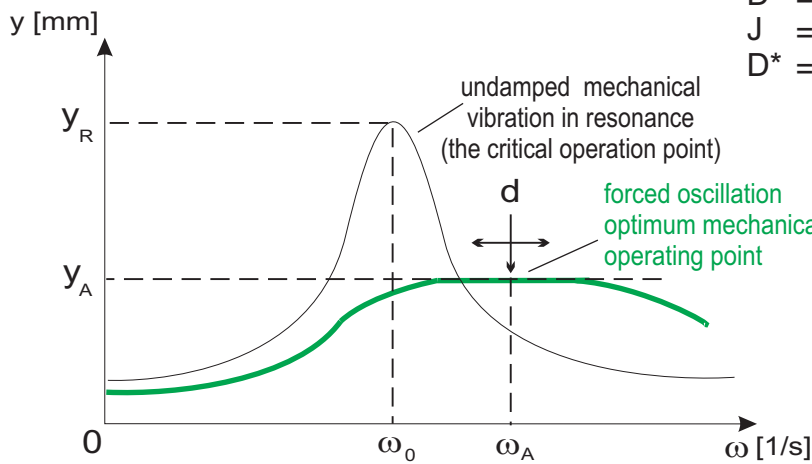

$$y = f(\omega)$$

$$y_A = f(\omega_A)$$

spiral feeder $\omega_0 \approx \sqrt{\frac{D^*}{J}}$

linear feeder $\omega_0 \approx \sqrt{\frac{D}{m_0}}$

$$\beta \approx k \cdot m_0$$

↑
over the critical operation point

General information

Adjustment of operating point on vibration systems
with high changes in weight

Diagramm 3

electrical operating frequenz ω_A
 $\omega_A = \omega_0 - \Delta 3,0 \text{ Hz}$
Result: $y_A = \text{constant}$

- y =elongation (excursion)
- y^R =elongation at mech. resonance
- y_A =elongation at ω_A
- ω =angular frequency
- ω_A =operating frequency, electrical
- ω_0 =mechanical resonance frequency
- d =attenuation
- m_r =resulting mass (weight)
- D =spring constant (spring)
- J =mass moment of inertia
- D^* =angular guide value $\frac{M_d}{\varphi}$

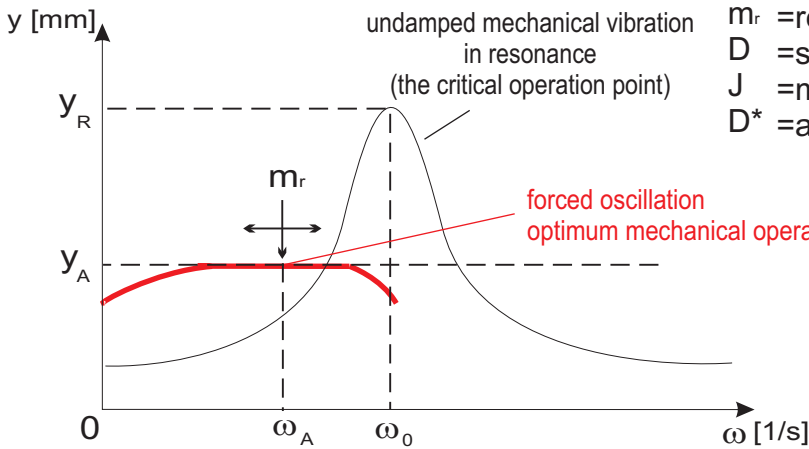

Constant feeding velocity with high changes in weight up to emptying
Pay attention to the slightly higher power input at this operating point

↑
below the critical operation point

$y = f(\omega)$

$y_A = f(\omega_A)$

spiral feeder $\omega_0 \approx \sqrt{\frac{D^*}{J}}$

linear feeder $\omega_0 \approx \sqrt{\frac{D}{m_r}}$

$d \approx k \cdot m_r$

Half-wave operation

Characteristic of the vibration
feeding system

$$f_0 = \frac{1}{2\pi} \sqrt{\frac{D_{ges}}{m_r} - \left(\frac{d}{2m}\right)^2}$$

d = Damping constant
D_{ges} = Total spring constant
m_r = Resulting mass of the oscillator and
resulting mass moment of inertia

Attention!

Pay attention to the following items in half-wave operation!

Optimum operating point of the oscillator

$$f_A = f_0 \pm \Delta 3,0\text{Hz}$$

As f_A can be selected with absolute stability by the Universal Resomat in the range of 4,0 – 99,9 Hz, the oscillator characteristic f₀ can be executed as a variable, standardized, mechanical value.

- In this operating mode the mechanical frequency changes to half the value
- The output current shows as pulsating direct current (d.c.)
- All other values are maintained.

Synchronous Operation

Synchronised Phase Resomat Applications

Synchronous Operation of Vibrating Conveyor Systems Reaction & Interference Force Compensation or Transition Gap Minimisation

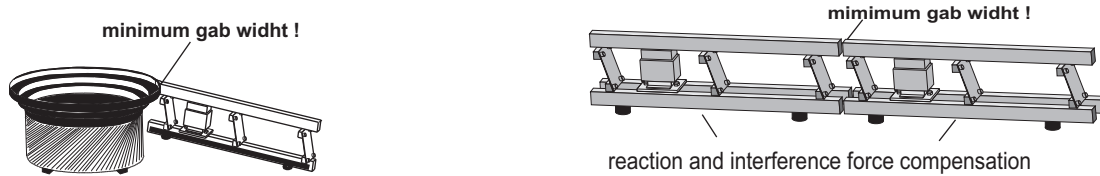

Mechanical operating point shift for synchronous operation of e.g. circular- and linear conveyors in conjunction with synchronous Resomats.

Electrical state RM7US output: $\frac{\omega_{A1}}{\text{Master}} = \frac{\omega_{A2}}{\text{Slave}} ; \Delta\varphi = \text{variable}$

Mechanical state of vibrator:

Time and phase shift φ between excitation ω_A (electrical power) and resonator (mechanical vibrator) on circular- and linear conveyors. The resonator follows with $\Delta\varphi$ lagging behind exciter function ω_A in the range $0^\circ - 180^\circ$.

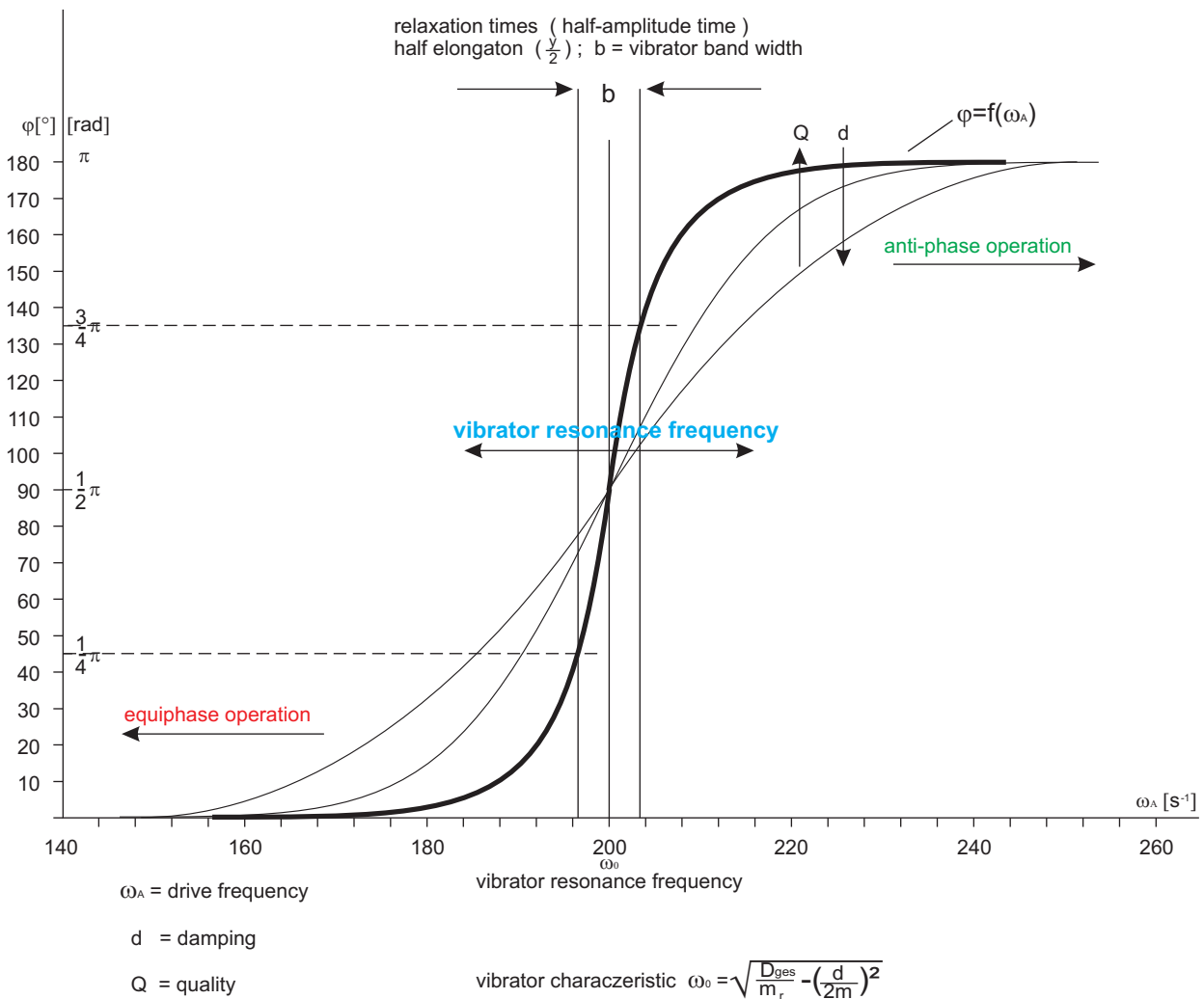

Anwendungen

Störkraftkompensation

Schwebungen (Interferenzen), Überlagerungen von mechanischen Störschwingungen bzw. Reaktionskräften führen oft zu Störungen im Förderfluß von gemeinsam montierten Schwingfördereinheiten. Die Wirkung der Störkraft ist abhängig vom Kopplungsgrad kaskadierter mechanischer Systeme als Störkraft- (Reaktionskraft)- Erzeuger. Abhilfe kann nach Ausschöpfung verschiedener mechanischer Maßnahmen wie z.B. Verbesserung von Dämpfungs- bzw. Abstützfunktion der Einzelsysteme, durch Verwendung von Master-Slave-Resomaten im phasenrichtigen Synchronbetrieb mit gutem Erfolg erreicht werden. Besonders bei der Verwendung von gleichartigen mechanischen Systemen lassen sich bei voller Nutzschwingung hohe Kompensationseffekte nachweisen, wobei die Anzahl der mechanischen Slave-Systeme beliebig ist.

Die Störkraft-Kompensation zwischen Rund- und Linearförderern ist an der Materialflußlinie ebenfalls mit gutem Erfolg möglich, da hier die Drehschwingung des Rundförderers als "Längsschwingung" wirkt. Siehe auch mathematischer Anhang 2.

Abb. 1

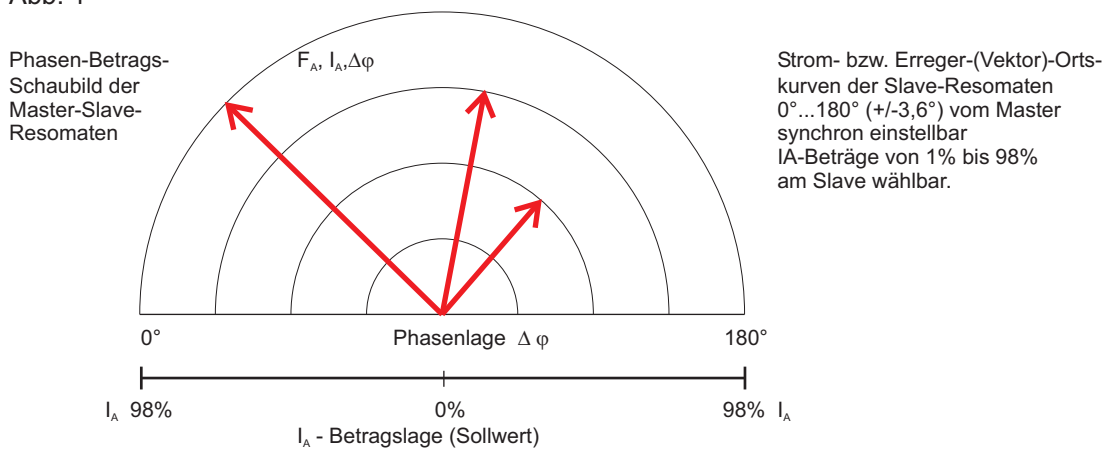

Master-Slave Verfahren zur Kompensation (Reduzierung) von Reaktionsschwingungen, Schwebungen, Störkräften und Reaktionskräften an mehrfach gekoppelten Rund-Linearfördersystemen. Null-Indikation der Störschwingungen (Reaktionskräfte) durch Synchronisation der Schwingfördersysteme bei gleichzeitigem Phasen- bzw. Betragsabgleich (siehe Abb.1) der angekoppelten Slave-Einheiten unter besonderer Berücksichtigung des mechanischen Schwingearbeitspunkt (siehe Abb. 2).

Abb. 2

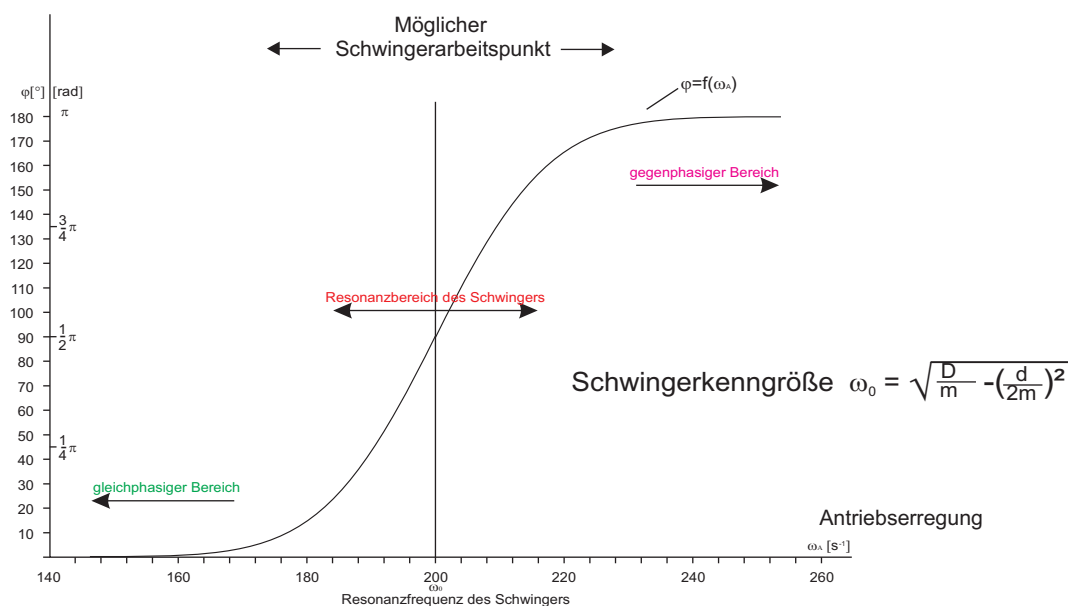

Synchronbetrieb

Anwendungen

Die Störkraft bzw. Reaktionsschwingungs-Kompensation erreicht dann ein Minimum, wenn die Störkraftvektoren der Einzelschwinger als resultierender Summenvektor nach Phase und Betrag gegen Null geht (siehe Abb. 3)

Abb. 3

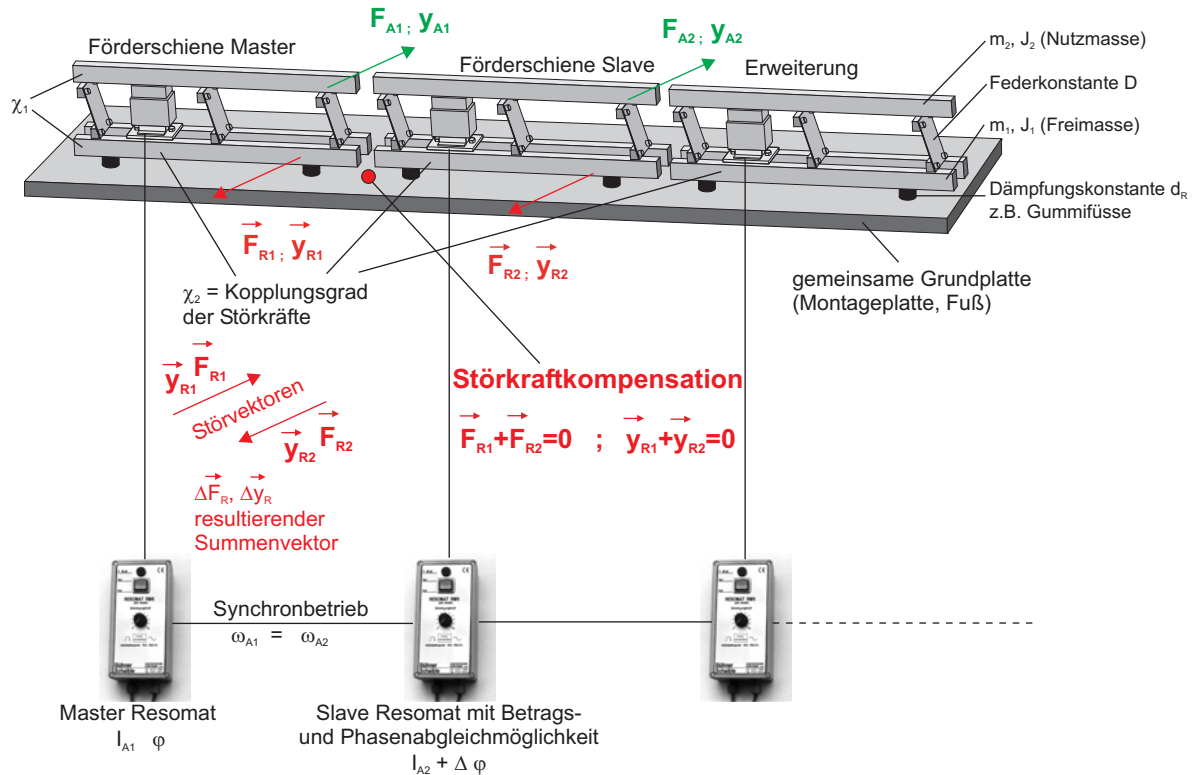

Erklärung:

ω_0	= mechanische Resonanzfrequenz (Schwingerkenngröße)	[Hz]
ω_A	= Antriebsfrequenz, Antriebserregung der Schwinger	[Hz]
I_A	= Erregerstrom von Master - Slave - Resomat	[A]
φ	= Phasenlage allgemein	[° o. rad]
$\Delta\varphi$	= Phasenverschiebung zwischen Master u. Slave-Resomat	[° o. rad]
y	= Elongation (mech. Schwingweg) allgemein	[mm]
y_{A1}	= Aktionselongation des Master-Schwingers (Nutzschwingung)	[mm]
y_{A2}	= Aktionselongation des Slave-Schwingers (Nutzschwingung)	[mm]
y_{R1}	= Reaktionselongation des Master-Schwingers (Störschwingung)	[mm]
y_{R2}	= Reaktionselongation des Slave-Schwingers (Störschwingung)	[mm]
F_{A1}	= Aktionskraft des Master-Schwingers (Nutzkraft)	[N]
F_{A2}	= Aktionskraft des Slave-Schwingers (Nutzkraft)	[N]
F_{R1}	= Reaktionskraft des Master-Schwingers (Störkraft)	[N]
F_{R2}	= Reaktionskraft des Slave-Schwingers (Störkraft)	[N]
K	= allgemeine Konstante	
χ_1	= Verhältnis der übertragenen Störschwingung zur Nutzschwingung	[%]
χ_2	= Kopplungsgrad der mechanischen Systeme (Störkraftfluß)	[%]
D	= Federkonstante	[N/mm]
m	= Masse	[kg]
J	= Massenträgheitsmoment	[kg mm ²]
d_R	= Dämpfungskonstante, Übertragungsdämpfung	[kg / s]
d	= Dämpfungskonstante der Feder	[kg / s]

Synchronbetrieb

Anwendungen

Math. Anhang 2

Der hier angeführte Begriff "Längsschwingung" ist eine vereinfachte Darstellung für die in Wirklichkeit vorhandene dreidimensionale, longitudinale, mechanische Reaktionsschwingung, die durch den komplexen Ausdruck

$$\mathbf{y}_R = \hat{\mathbf{y}}_R e^{j\omega t + \varphi}$$

beschrieben werden kann.

Sie wird erzeugt durch eine an der Feder (mit der Federkonstante D) wirkenden, stromproportionalen, magnetischen Erregerkraft von der Form

$$\mathbf{F}_R = \mathbf{K} \hat{\mathbf{I}}_A \sin \omega t$$

Der Betrag der Reaktionsschwingung y_R ist nach dem Schwerpunktsatz eine Funktion der Massen- bzw. Massenträgheitsmoment-Verhältnisse der mechanischen Schwinger. Es verhält sich die Aktions- schwingung y_A zur Reaktionsschwingung y_R umgekehrt (reziprok) wie Nutzmasse m_2 zur Grund- bzw. Freimasse m_1 bzw. die entsprechenden Trägheitsmomente J_2 und J_1 zueinander. Es ist

$$\frac{m_2}{m_1} = \frac{y_R}{y_A} \quad \text{bzw.} \quad \frac{J_2}{J_1} = \frac{y_R}{y_A}$$

somit ergibt sich:

- | | | | | |
|----|---|--|------|------------------------------------|
| a) | die Aktions- (Nutz) Schwingung | $y_A = \frac{m_1 y_R}{m_2}$ | bzw. | $y_A = \frac{J_1 y_R}{J_2}$ [mm] |
| b) | die Reaktions- (Stör) Schwingung | $y_R = \frac{m_2 y_A}{m_1}$ | bzw. | $y_R = \frac{J_2 y_A}{J_1}$ [mm] |
| c) | Reaktionsanteil in % zur Gesamtschwingung | $\chi_1 = \frac{100 y_R}{y_A + y_R}$ | | [%] |
| d) | Übertragungsfaktor (Kopplungsgrad) der mech. Systeme z.B. über Gummifüße (Störkraftfluß als Funktion des Dämpfungsfaktor) | $\chi_2 = \frac{1}{d_R} \mathbf{K}$ | | [Faktor] |
| e) | Bedingung für die Nullindikation: | | | |
| | Störschwingung des 1. Systems: | $\mathbf{y}_{R1} = \hat{\mathbf{y}}_{R1} e^{j \omega t}$ | | Master |
| | Störschwingung des 2. Systems: | $\mathbf{y}_{R2} = \hat{\mathbf{y}}_{R2} e^{j \omega t + \varphi}$ | | Slave |
| | Systembeeinflussung gegenseitig: | $\mathbf{y}_{R1} \pm \chi_2 \mathbf{y}_{R2}$ | | für Master |
| | | $\mathbf{y}_{R2} \pm \chi_2 \mathbf{y}_{R1}$ | | für Slave |
| | Reststörung nach Nullindikation:
(Nach Phasen- u. Betragsabgleich) | $\Delta \vec{\mathbf{y}}_R = \chi_2 (\vec{\mathbf{y}}_{R1} \pm \vec{\mathbf{y}}_{R2})$ | | [mm] |

In der Praxis zu beachten:

Bei großen χ_2 Werten, z.B. durch Metallfüße an den Einzelsystemen, ist keine Kompensation möglich. Problemlösung hier durch gezielt phasenverschobenes, synchrones Einzeltreiben der Schwingsysteme (Siehe Laborbericht 3/0)

Anwendungen

Mathematisch- physikalischer Anhang zur Minimierung des Übergangsspalt gekoppelter Schwingfördersysteme

Abb. 4

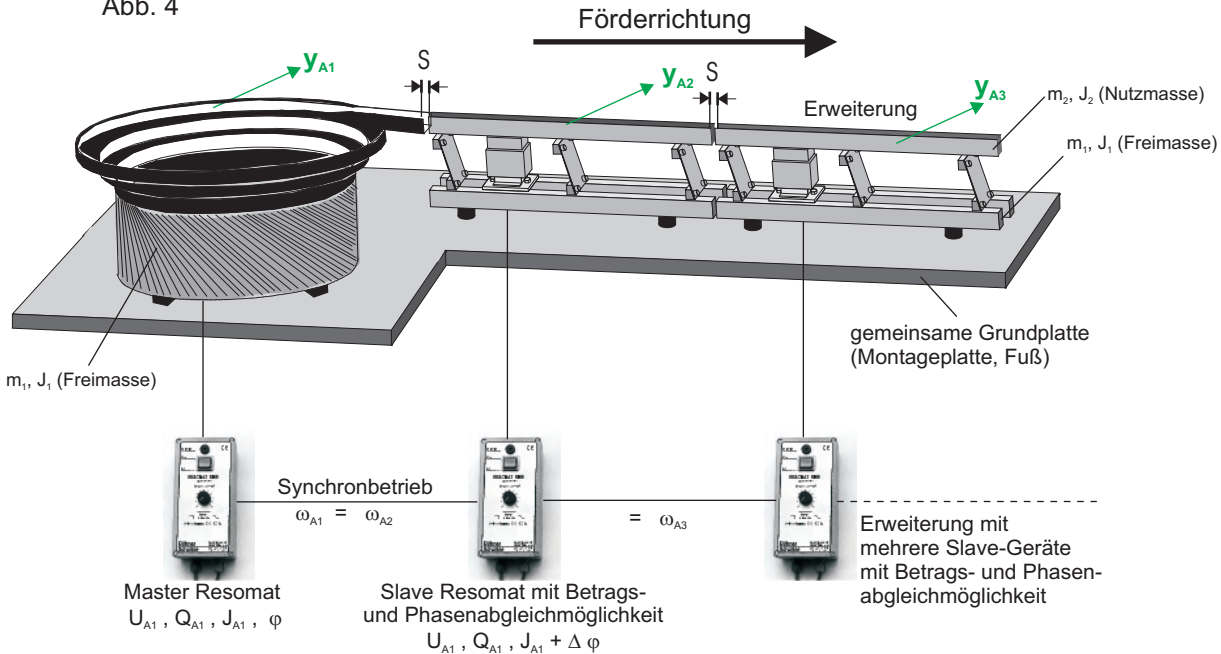

Die Aktionsschwingungen (Nutzschwingungen, Elongation) y_A sind verantwortlich für den Förderfluss. Die Übergangspaltsituation S an den Übergängen gekoppelter Schwingensysteme kann bei kritischen Förderteilen, selbst im synchronen Förderbetrieb, noch problematisch sein (Anschlag bzw. Berührungseffekte, Spaltvergrößerung, gegenläufige Bewegung usw.).

Der Grund hierfür ist die vom Schwingerarbeitspunkt abhängige mech. Phasenlage der Schwingensysteme (siehe Abb. 2).

Abhilfe ist durch Verwendung von synchronarbeitenden Master - Slave Resomaten mit variabler Phasenlage möglich. Hierbei kommt es darauf an, dass der differentielle mechanische Bewegungsablauf der Einzelsysteme synchron, betrags- und phasenmäßig absolut gleich verläuft.

Erklärung:

- Der Förderfluss bzw. die Fördergeschwindigkeit v ist eine Funktion der Elongationen $y_{A1}, \dot{y}_{A1}, y_{A1}$ usw.; $v = f(y)$
- Die Elongation y ist eine harmonische Bewegung und ergibt sich zu:
 $y = \hat{y} \sin \omega t$
- Die Synchronität der Einzelsysteme wird beim Master - Slave Verfahren durch den Ausdruck $\omega_{A1} = \omega_{A2} = \omega_{A3}$ usw. dargestellt und vereinfacht als Arbeitsfrequenz ω bzw. f bezeichnet. Siehe auch Laborberichte Arbeitspunkteinstellung an Schwingfördersystemen.
- Die spezifischen mechanischen Phasenlagen der Elongation werden mit $\Delta\varphi_{A1}, \Delta\varphi_{A2}, \Delta\varphi_{A3}$ bezeichnet und verändern den dazugehörigen Bewegungsablauf zueinander.
Es ist daher:
 $y_{A1} = \hat{y}_{A1} \sin \omega t + \Delta\varphi_{A1}$
 $y_{A2} = \hat{y}_{A2} \sin \omega t + \Delta\varphi_{A2}$
 $y_{A3} = \hat{y}_{A3} \sin \omega t + \Delta\varphi_{A3}$ usw.
- Der Übergangspalt gekoppelter Systeme wird dann zum stabilen Minimumwert ($S \rightarrow 0$) wenn die Bedingung $y_{A1} = y_{A2}$ und $\varphi_{A1} = \varphi_{A2}$ usw. durch entsprechenden Betrags- und Phasenabgleich der synchronisierten Resomat-Stellgliedern durchgeführt wird.
Bei optimalen mechanischen Bedingungen sind Übergangsspalte von $<0,1\text{mm}$ möglich.

Technicel Data

Model	RM7U, RM7U-10, RM7 Labor
Conected voltage	230V oder 115V , +10% / -15% 50/60Hz
Drive frequency (also half-wave operation)	10 - 200,0 Hz digitally adjustable in 0,1 Hz increments (quarz stabilisedl)
synchronous operation Phase setting of synchronised output adjustable values	For several Resomats in synchronous operation Phase angles between the units from 0° to 360° adjustable in 3.6° increments
Output current (vibration amplitude)	Full sine wave symmetrical alternating current, full or half wave operation selectable or clipping selectable (turbo effect)
Continuous current	6 A_{eff} , 10A with heat sink and ventilator
Soft start / Soft stop	0 - 5s adjustable
Optocoupler input Lock / relase	24 VDC 10mA (can be inverted)
Contact input Lock / relase	Poential-free contact Contact load 12V, 10mA (can be inverted)
Reference value input	10K potentiometer or 0-10V (Ri approx. 10K)
Sensor inputs	24V DC , PNP for one or two sensors (min / max) can be inverted
Sensor supply	24V max. 100mA
Switch-on delay	0,1 bis 10 s.
Swicht-of delay	0,1 bis 10 s.
24V DC - output	24V DC - 200mA (c.g. pneumatic valve)
Switching output	potential-free change-over contact 250V / 0,5A AC Alternatively, transistor output 24VDC 20mA
Error message output Error message time = 30 s.	Potential-free NO contact 250V / 0,5A AC Alternatively, transistor output 24VDC 20mA
Temperature range	0 - 40°
Protection type	IP 54
Dimensions	Aluminium casing 200 x100 x 80 mm Drill pattern 187 x 87 mm(187 x 66mm)

Technicel Data

Model	RM7, RM7-10, RM7 Labor
Conected voltage	230V oder 115V , +10% / -15% 50/60Hz
Drive frequency (also half-wave operation)	10 - 200,0 Hz digitally adjustable in 0,1 Hz increments (quarz stabilisedl)
synchronous operation Phase setting of sychronised output adjustable values	For several Resomats in synchronous operation Phase angles between the units from 0° to 360° adjustable in 3.6° increments
Output current (vibration amplitude)	Full sine wave symmetrical alternating current, full or half wave operation selectable or clipping selectable (turbo effect)
Continuous current	6 A_{eff} overload protection 10Awith heatsink and ventilator
Soft start / Soft stop	0 - 5s adjudtsble
Optocoupler input Lock / release	24 VDC 10mA (can be inverted)
Contact input Lock / release	Poential-free contact Contact load 12V, 10mA (can be inverted)
Reference value input	10K potentiometer or 0-10V (Ri approx. 10K)
Temperature range	0 - 40°
Protection type	IP 54
Dimensions	Drillpattern 187 x 87mm (187 x 66mm) Aluminium casing 200 x 100 x 80mm

Synchronisation connections

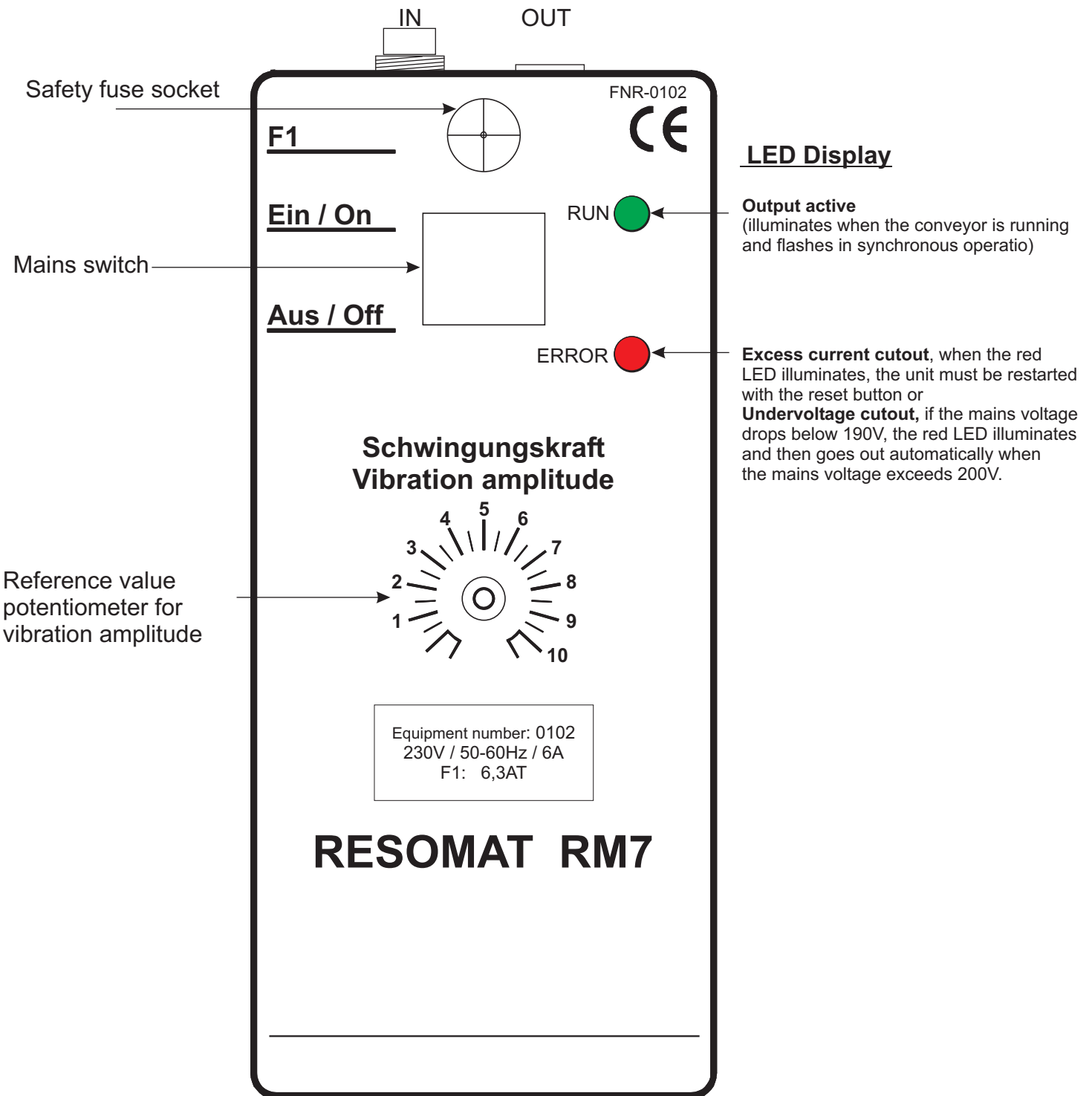

LED Display

Output active
(illuminates when the conveyor is running and flashes in synchronous operation)

Excess current cutout, when the red LED illuminates, the unit must be restarted with the reset button or
Undervoltage cutout, if the mains voltage drops below 190V, the red LED illuminates and then goes out automatically when the mains voltage exceeds 200V.

Synchronisation connections

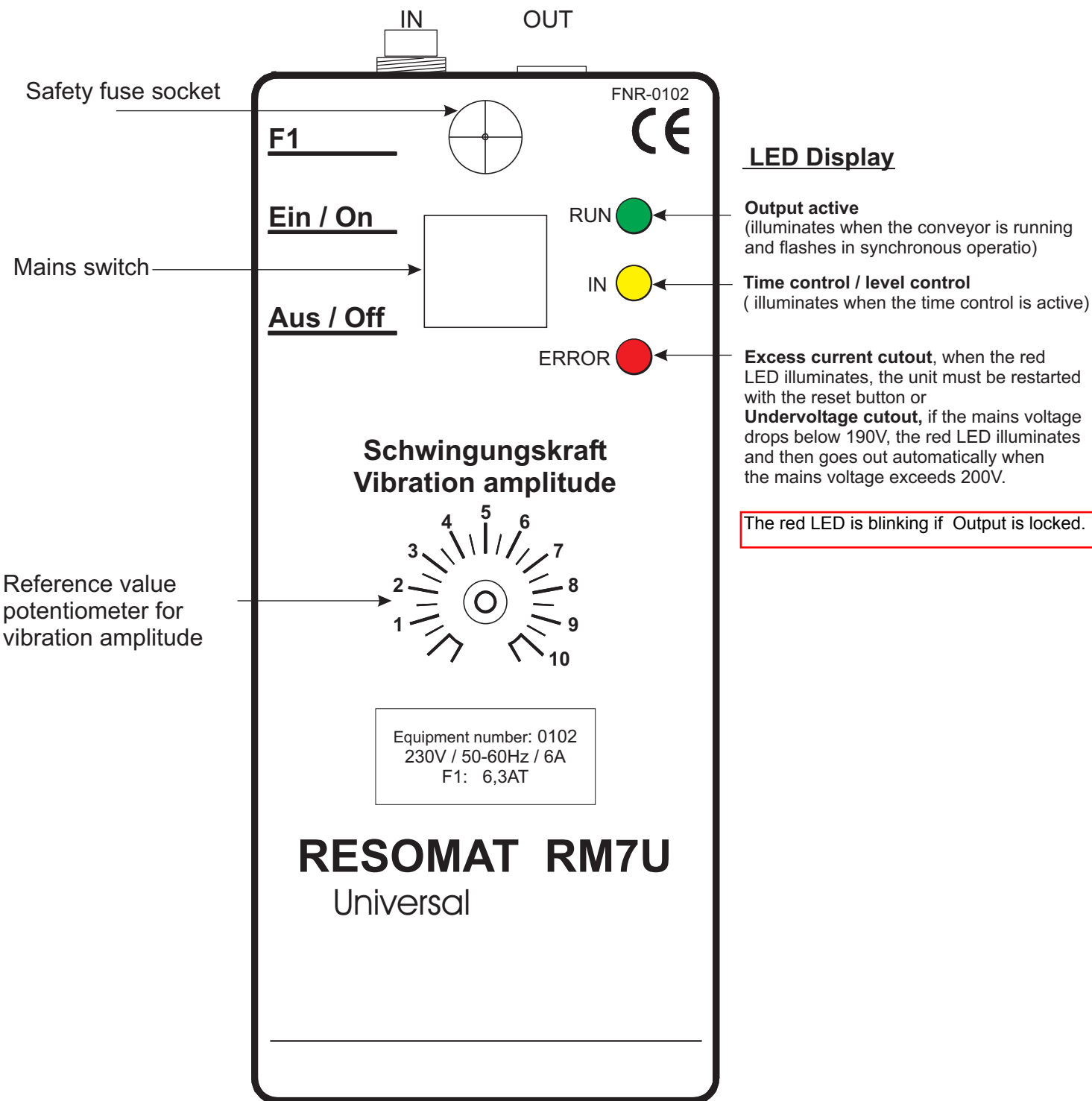

Frontpanel specification RM7U LABOR

Synchronisation connections



Safetyfuse socket

F1

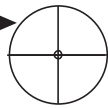

FNR-0102L



Ein / On

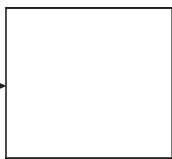

RUN

LED Display

Output active
(illuminates when the conveyor is running and flashes in synchronous operation)

IN

Time control / level control
(illuminates when the time control is active)

ERROR

Excess current cutout, when the red LED illuminates, the unit must be restarted with the reset button or
Undervoltage cutout, if the mains voltage drops below 190V, the red LED illuminates and then goes out automatically when the mains voltage exceeds 200V.

Mains switch

Aus / Off

RM7U LABOR

Schwingungskraft
Vibration amplitude

Reference value potentiometer for vibration amplitude

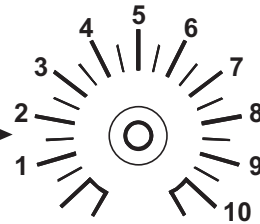

Equipment number: 0102L
230V / 50-60Hz / 6A
F1: 6,3AT

Ausgangs-Stromform

Frequenz				Phasenwinkel $\Delta\phi \times 2$ in Grad °		Ausgangs-Stromform	
100	10	1	0.1	36°	3.6°	+ Full wave	- Half wave
<input type="checkbox"/>	<input type="checkbox"/>	<input type="checkbox"/>	<input type="checkbox"/>	<input type="checkbox"/>	<input type="checkbox"/>	<input type="checkbox"/>	<input type="checkbox"/>
0	5	0	0	0	0	+	+
<input type="checkbox"/>	<input type="checkbox"/>	<input type="checkbox"/>	<input type="checkbox"/>	<input type="checkbox"/>	<input type="checkbox"/>	<input type="checkbox"/>	<input type="checkbox"/>
<input type="checkbox"/>	<input type="checkbox"/>	<input type="checkbox"/>	<input type="checkbox"/>	<input type="checkbox"/>	<input type="checkbox"/>	<input type="checkbox"/>	<input type="checkbox"/>

+ Full wave
 - Half wave
 + Full wave
 - Turbo

Equipment Specification

Conveyor Connection

The equipment is protected by an external 16A (K) standard safety cutout.

The control unit is fitted with a shockproof plug and a shockproof coupling.

The shockproof plug is for the control unit power supply.

The shockproof coupling shall be plugged into the vibrating conveyor connecting cable.

Potential Settings

Selector Switch 1 "Half Wave"

The "full wave" and "half wave" operating modes can be selected with this selector switch. The information on Page 7 should be read without fail in conjunction with the "half wave" setting. Full wave "OFF", half wave "ON".

Selector Switch 2 "Turbo"

This enables selection of the output current pulse shape. The sinusoidal shape is often more advantageous for circular and the triangular shape for linear conveyor systems. Sinusoidal "ON", turbo (triangle) "OFF".

Selector Switch 3 "Control Input Inversion" (Control Input Lock / Release)

Attention! Start / stop operation only via control input!

The control input is designed for 24VDC (connection in accordance with wiring diagram Page 18). The control input can be inverted using switch 3 on the unit (Lock / Release). If the selector switch is set to "OFF" and 24VDC is connected to the optocoupler input, the control unit output switches off. If the selector switch is set to "ON", the output switches on when 24VDC is connected to the optocoupler input.

If the control input is not used, the selector switch must be set to "OFF".

Potentiometer - ts on / ts off - "Smooth Start / Smooth Stop"

The smooth start is active at the switch-on moment and is used to increase the conveyor power on a timed basis so that e.g. the material arranged on the conveyor does not change its position at the switch-on moment. The smooth stop is active at the switch-off moment and is used for timed switching-off of the conveyor power. The duration of the smooth start or the smooth stop is approx. 0 to 5 sec. (adjustable). If a smooth start or smooth stop should not be active, the potentiometers must be set to 0.

Selector Switch 4 "Sensor 2 Inversion"

To invert the sensor signal at the input.

Selector Switch 5 "Sensor 1 Inversion"

To invert the sensor signal at the input.

Frequency Switch

The frequency can be set in 0.1Hz increments in the 10Hz to 200.0Hz range using the frequency switches (100, 10, 1, 0.1)

Reference Value / Limit Potentiometer

The trimmer potentiometer on the front panel is the reference value potentiometer.

The limit potentiometer on the top panel of the casing is responsible for its presetting.

The reference value can be set alternatively at 0-10V DC from an external voltage source. (See wiring diagram)

Synchronous Operation (See Wiring Diagram)

If a synchronisation signal is on in synchronous operation, the green "Operation" LED flashes.

Up to 5 units can be synchronised with the appropriate synchronisation cables.

The drive frequency must be set identically on all synchronised units.

The master may not be controlled with the start / stop signal in master / slave operation.

The OMSP 1 phase testing unit is recommended to test the phase sequence of synchronised systems.

Equipment Specification

Excess Current Cutout

If the nominal current is exceeded by a long way, the equipment switches off and the red **ERROR LED** illuminates. The equipment is switched on again using the RESET button on the front panel, Or inside of the device on the top panel.

Undervoltage Display / Mains Monitoring

If the mains voltage drops below 190V, the equipment switches off automatically and the **ERROR LED** illuminates. When the mains voltage rises above 200V again, the equipment starts up automatically and the ERROR LED goes off.

Level Control (Minimum Sensor = Sensor 1) (Not applicable to RM7)

The level control controls the running time of the circular conveyor in such a way that unnecessary running times are avoided. The circular conveyor is switched on and off via internal adjustable times ("t off" and "t on") depending on the material level measured by a material sensor. The level of the material to be conveyed fluctuates around the position of the material sensor fitted in the filling section. The power output of the frequency control unit is switched on when the material to be conveyed falls short of the sensor and the preset switch-on delay time has expired. Now material is conveyed again into the filling section. If the material to be conveyed exceeds the position of the sensor, the switch-off delay is started and upon expiry thereof the power output of the frequency control unit is switched off again.

Gaps in the material flow reset the times respectively so that the times are always determined by the last or first material section. The switch-on and off delay times can be set externally at the "t off" or "t on" trimmer capacitors.

In order to increase the material backlog downstream of the sensor, the switch-off time of the frequency control unit is extended by the "t off" trimmer capacitor. The material backlog is reduced by shortening the "t off" time. The time, which elapses when the last component leaves the sensor until switching-on of the circular conveyor, can now be determined using the "t on" trimmer capacitor. (See Wiring Diagram Page 17)

Minimum / Maximum Control (Not applicable to RM7)

A minimum / maximum control can be achieved using a second sensor, which can be connected to the frequency control unit. (Maximum sensor = Sensor 2)

Error Message Output (Not applicable to RM7)

At the same time as the switch-off delay, an error time is started, which the Resomat control unit or an external PLC switches as required after a period of 30 seconds, if no component has reached the sensor during this time. This time should not prevent any possible disconnection with empty circular conveyor or jammed components. (See Wiring Diagram Page 17)

Output Selection (Not applicable to RM7)

Delivery condition: transistor output TA as error message time and relay as level control (preset in factory).

Further Potential Settings (Not applicable to RM7)

It is possible to invert sensor inputs. The frequency control unit output is switched off in the non-inverted state with damped sensor. The output is switched on in the inverted state with damped sensor. These settings can be made inside the device using selector switches 4 and 5.

Wiring diagram for RM7

Resomats in Synchronous operation:
 - two-core cable max. 1m



Terminal Allocation:

Bottom Panel

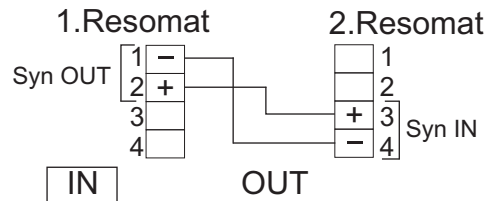
1 A	Output
2 A	Attention! *
3 PE	Protective conductors
4 PE	
5 PE	
6 L	Mains input
7 N	See nameplate!



Top Panel

9 +	24VDC 200mA
10 -	
12 +	24VDC 200mA
13 -	
14 +	Optocoupler control
15 -	Input 24VDC Lock/release
16 +	 1 reference value
17 SL	
18 -	
19 +	

Smooth stop
Smooth start

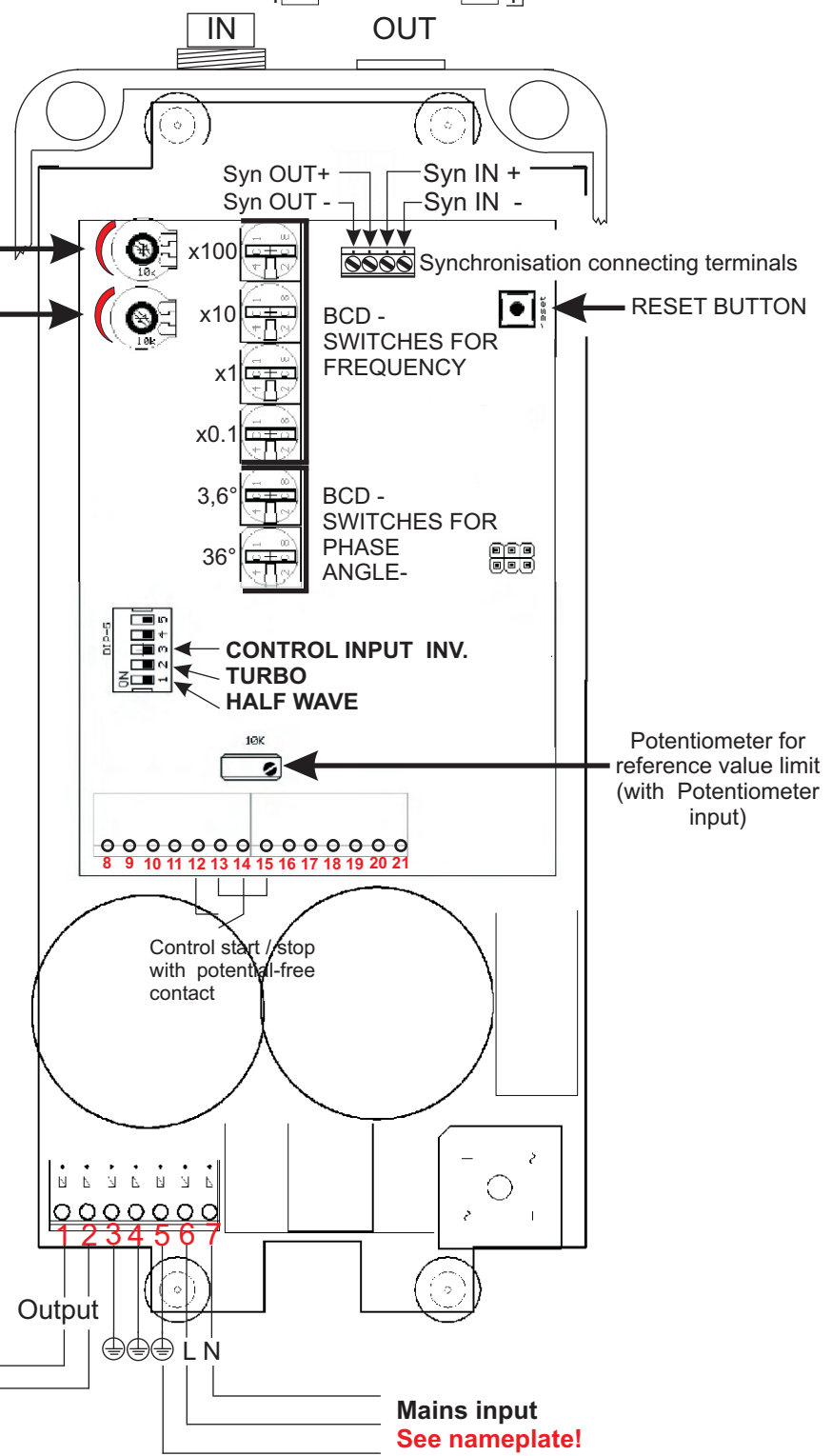

***Attention !!**
 Do not connect output to N!!

Mains input
See nameplate!

Wiring diagram for RM7U, RM7 Labor

Resomaten in synchronous operation:
- two-core cable max. 1m

Terminal allocation

Bottom Panel

1 A	Output
2 A	Attention!*
3 PE	Protective conductors
4 PE	
5 PE	
6 L	Mains input
7 N	See nameplate!

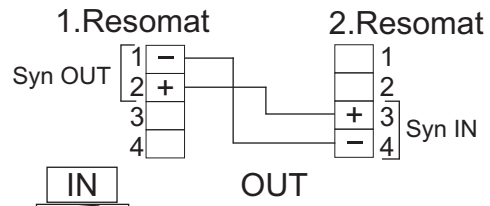

Top Panel:

8 In	Level control
9 +	1 Sensor
10 -	24VDC 200mA
11 In	Level control
12 +	2 Sensor for min/max Control
13 -	24VDC 200mA
14 +	Optocoupler control
15 -	Input 24VDC Lock / Release
16 +	1. Reference value Reference value Poti 10K
17 SL	
18 -	2. Reference value 0 - 10VDC
18 -	
19 +	External voltage source
20 -	Transistor output +24VDC 20mA
21 +	
22	Status relay
23	
24	

Soft Stop

Soft Start

switch-off delay
0-10s(backlog control)

switch-on delay
0-10s(backlog control)

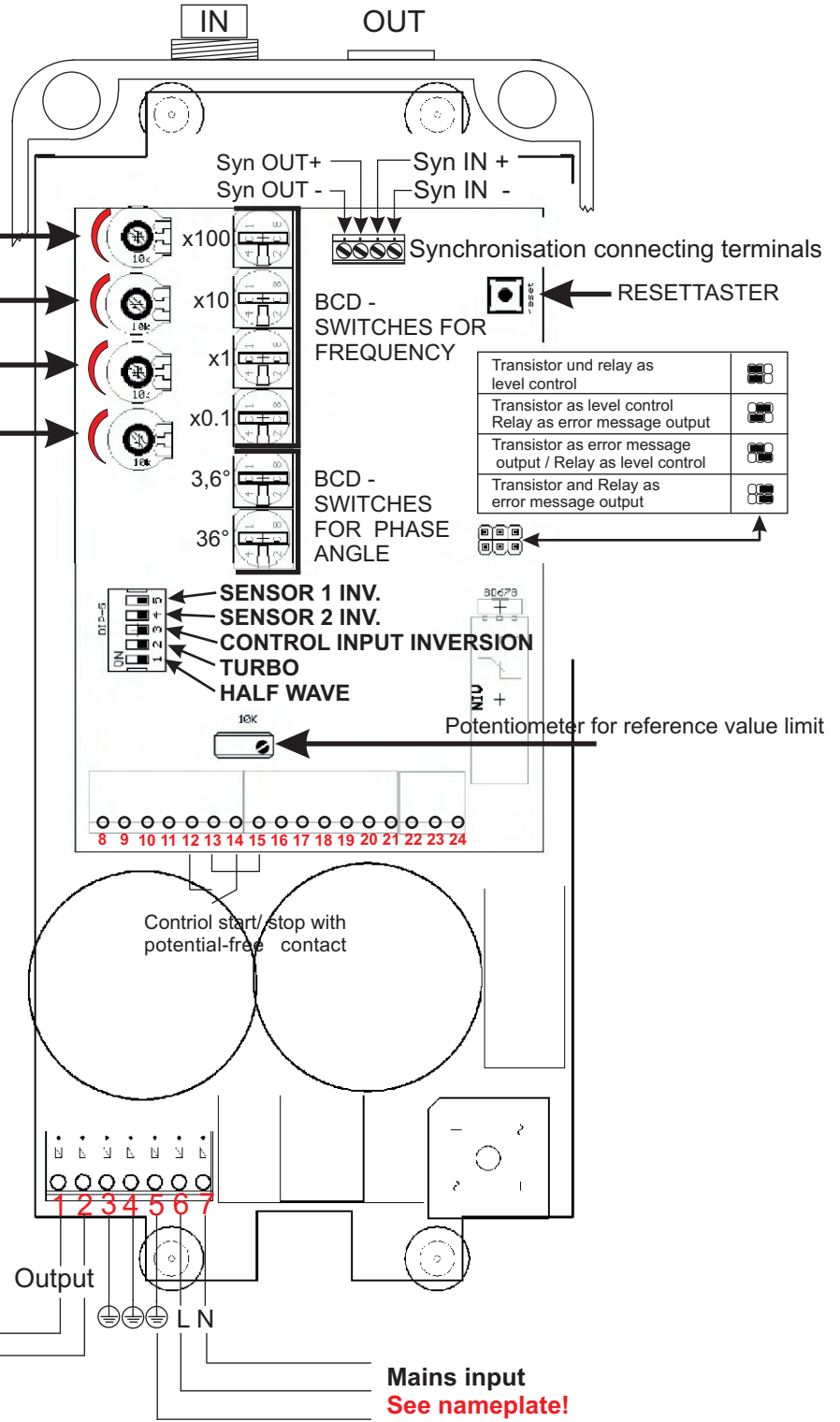

***Attention !!**

Do not connect output to N !!

Mains input
See nameplate!

Error Analysis

Equipment does not work:

- Check whether mains voltage is present.
- Set "Lock / Release" control input inversion correctly.
If this input is not used, the selector switch must be set to "OFF".
- Red ERROR LED illuminates.
Excess current cutout active, nominal current has been far exceeded.
Equipment switches off automatically.
The equipment is switched on again using the RESET button on the front panel , or inside of the device on the top panel.
- Red ERROR LED illuminates.
If the mains voltage drops below 190V, the equipment switches off automatically. Upon mains recovery to 200V upwards, the equipment starts up again automatically and the ERROR LED goes out.

No power on conveyor:

- Check whether the correct output frequency has been set (See Pages 4/5/6 for setting instructions).
Check reference value settings.

Conveyor vibrates depending on load:

- Check whether the correct output frequency has been set (See Pages 4/5/6 for setting instructions, operating point setting on vibrating systems).

Magnet gets hot:

- Magnet has incorrect mains voltage, check.
- The power absorption of the magnet is too high due to incorrect mains voltage or too great an air gap, check.
The input current on the vibrating systems is measured expediently using the set of measuring instruments or current meters (moving-iron measuring instruments).
- Magnetic reversal losses may be too high when using DC magnets.
—————→ improvement with half-wave operation

Technical Assistance:

- Application assistance, technical advice with problems on circular and linear conveyors.

The Universal Phase Resomat RM7

The Universal Phase Resomat RM7 is a logical continuation of the tried and tested RM6 Resomat family. This new Resomat generation enables the realisation of optimum inertial systems for feed technology due to its universality in conjunction with basic mechanical vibrator units.

The RM7 development engineers, *I. Rogowski* and *K. Minks*, were already striving in the forefront of this new RM concept to allow the experience gained in practice (with the already existing Master / Slave Resomats) to be included in the new development. The result of this design facilitates the solution of problems which can occur with multi-connected vibrating systems.

Multi-connected and also coupled vibrator mechanisms are subject to the law of superimposition which is well known from physics ("Definition of Vibrators with Several Degrees of Refinement"), where faults in material flow behaviour of conveyor components can occur very often in practice. These faults are confirmed primarily by the long-term behaviour of existing feed systems, when, for example, connecting and coupling configurations can be changed by environmental influences (e.g. hardening of rubber feet). These interference effects influence the factors (components) of conveying speed and motion characteristics via vectorial additions such that e.g. switching-off, stopping, bouncing or reversing effects etc. may occur in the materials being handled.

The new Resomat generation with the options of "frequency synchronicity with simultaneous individual absolute value and phase definition" of the individual mechanical systems via exciter forces fulfils the complex requirements of cascade vibrating feed systems. (See also Laboratory Report 8/00 Summary)

The conscious inclusion of the basic mechanical drives (taking into consideration the vibration characteristics mentioned in Laboratory Report 5/00) in the new Resomat concept (designated as standardised inertial system) leads to:

- a) Cost savings in the production of basic vibrating conveyor units
- b) Operating cost savings in electrical power supply
- c) Improvement in the overall material flow quality with the most varied conveying problems
(See also Universal Phase Resomat Rm7 brochures)

EC - Conformity Statement

For the following product designated as

Frequency Control Unit type Resomat RM5, RM5-10, RM6, RM6-10 and RM6U, RM6U-10
RM7, RM7U, RM7-10, RM7U-10 RM7S, RM7US with vibration feeding devices

we hereby confirm that it is in accordance with the essential safety regulations which have been determined in the guidelines of the council for the adaption of the legal regulations of the member states regarding the electromagnetic compatibility, EMC (89/336/ECC).

This statement is in force for all units that are manufactured according to the enclosed drawings which are part of this statement. For the evaluation of the product relating to EMC, the following standards were applied:

EN 55011 -A	IEC 801-2
EN 50082-2	IEC 801-3
EN 60204	IEC 801-4

This statement is made in responsibility for the manufacturer/importer

**ASP Automationstechnik
Ing. Walter Prenner
A-7111 Parndorf, Dammgasse 13**